



SOL•THOR

0-3.6
kW

DC

1-10

IP 54

Utilize solar power directly for heat generation.

The SOL•THOR is a 3.6 kW DC power manager for photovoltaic heat. The self-sufficient water heating system utilizes every watt from the photovoltaic modules directly. The SOL•THOR linearly controls the connected heating elements from 0 to 3.6 kW to maximize the yield of photovoltaic heat.



- Maximum power: 0 - 3.6 kW, linear control
- Utilize 100% solar power
- No grid operator approval required
- Stratification heating possible with 2 heating elements
- Optional hot water backup
- Easy to retrofit into existing systems
- Compatible with conventional electric boilers
- Intuitive operation thanks to the display
- Straightforward installation (outdoor installation possible)
- Cheaper than conventional water heating
- Maintenance-free due to cables instead of pipes
- Communication: LAN + WLAN + RS485

How the SOL•THOR works

The SOL•THOR is a 0 – 3.6 kW linearly regulated DC power manager for solar-electric heat generation. Due to its self-sufficient operation, it does not require a connection to the power grid, as the device independently supplies itself from the PV generator. The DC power manager uses the photovoltaic electricity from the solar modules directly for heat generation – without grid feed-in, inverters, or grid operator approvals.

Performance

The SOL•THOR can be flexibly used with a PV system ranging from 1 to 10 PV modules. To ensure hot water supply, the DC power manager can optionally switch to grid power for additional heating. The device efficiently uses solar power by transferring the direct current from the photovoltaic modules almost loss-free to a connected heating element and converting it into heat. Additionally, it is possible to alternately control two heating elements.

Areas of application

In single-family homes

The simplest way to retrofit for ecological and economical heating in a single-family home: the SOL•THOR linearly controls heating elements and is also compatible with conventional electric boilers.

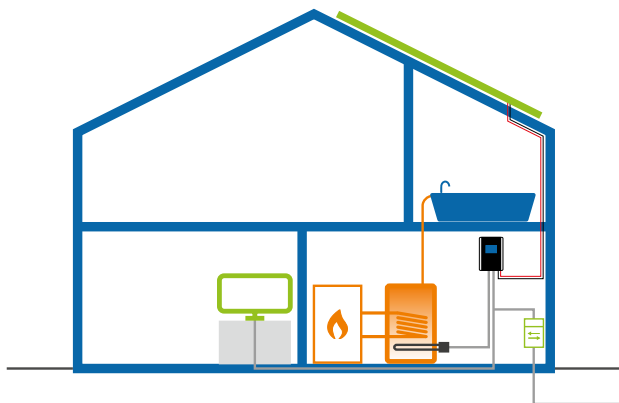

In residential construction

In multi-family homes, the installation of grid-connected PV systems is often too complex. The SOL•THOR is the ideal solution to supply each apartment completely independently – even with conventional electric boilers.

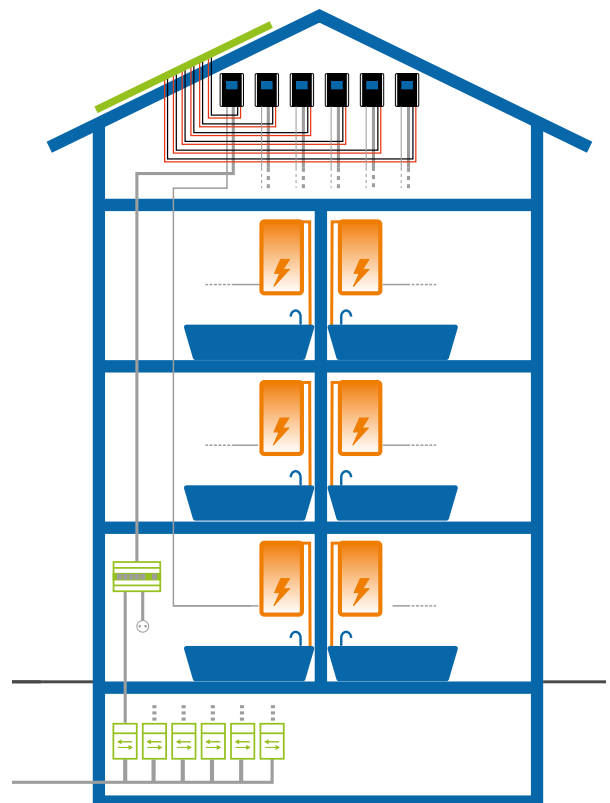

Additional areas of application

In general, the use of the device is ideal for projects with hot water needs in rural or off-grid environments.

Standard installation

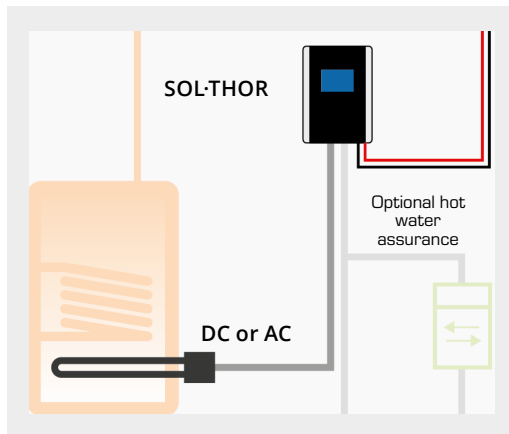

Stratification charging

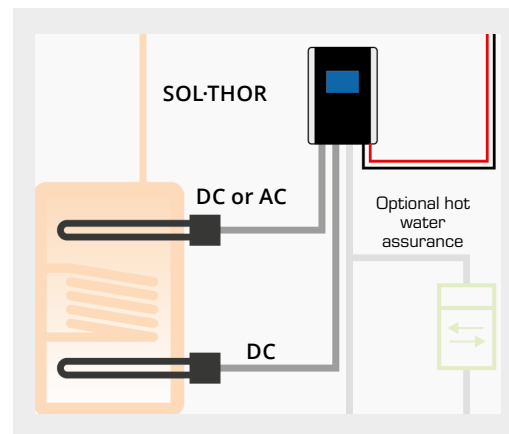

Technical specifications

- Parallel connection of up to 2 module strings
- Input current of up to 26 amperes
- Input voltage range: 30 to 230 volts
- Waterproof construction suitable for use in all weather conditions and for outdoor installations

Advantages over solar thermal systems

- Easy installation: only electrical cables, no piping
- Virtually no losses between PV generator and heat storage
- Maintenance-free: no moving parts, no antifreeze checks
- Higher yield from PV modules at lower ambient temperatures
- No stagnation issues, restarts automatically

How large should the photovoltaic system be?

For a solar coverage rate of 50% over the year, the following dimensions of the PV system are required (assuming a hot water demand of 50 liters per day per person):

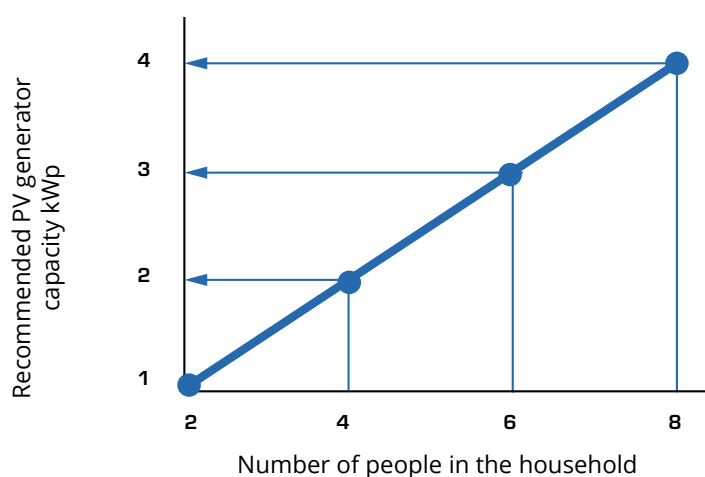

Technical Data

DC Operation

Start voltage	36 VDC								
MPP voltage range	30 - 220 VDC								
Maximum input voltage	230 Voc								
Maximum input current	26 A (current-limited)								
Maximum short-circuit current (ISC)	32 A								
Linear output max.	0 - 3,600 W, two outputs, alternately adjustable, max. 3,600 W at 25°C ambient temperature; derating in case of overheating								
Number of MPP trackers	1								
DC inputs	2 parallel, MC4 compatible connectors								
Power curve at max. input current as a function of input voltage	<p>The graph shows the power output (P) in Watts as a function of input voltage (V) in Volts. The x-axis ranges from 30V to 230V, and the y-axis ranges from 0W to 3600W. The power starts at 780W at 30V, increases linearly to 3600W at 138V, remains constant at 3600W until 230V, and then drops to zero.</p> <table border="1"> <thead> <tr> <th>Voltage (V)</th> <th>Power (W)</th> </tr> </thead> <tbody> <tr> <td>30</td> <td>780</td> </tr> <tr> <td>138</td> <td>3600</td> </tr> <tr> <td>230</td> <td>3600</td> </tr> </tbody> </table>	Voltage (V)	Power (W)	30	780	138	3600	230	3600
Voltage (V)	Power (W)								
30	780								
138	3600								
230	3600								

AC operation (optional for temperature assurance)

Heating power max.	3,600 W
Self-consumption during pure AC operation	approx. 2 W
Grid connection	Single-phase, max. 4 mm ² , 230 V, 45 - 65 Hz
AC fusing	max. 16 A, tripping characteristic B

General data

Load connections	Clamp contacts, single-phase, max. 4 mm ²
Display	Color Graphic, Touch Screen 2.83"
Interfaces	Ethernet RJ45, WLAN, RS485; Two potential-free switching outputs; 3 external temperature sensors;
External temperature sensor	Sensor dimensions: 20 x 5 mm, Cable length: 5 m, One piece included in delivery
Protection class	IP 54
Dimensions (W x H x D)	248.5 x 167.4 x 116.2 mm (including wall mount)
Weight	2.95 kg (including wall mount)
Operating temperature range	-20 °C to 60 °C
Storage temperature	-20 °C to 70 °C
Installation position	Vertical, wall-mounted
Warranty	2 years
my-PV article number	14-0100